



A Study of Fuel Consumption Model Using Tugboat's Propulsion System*

Hiroyasu Kifune** Takaaki Nishio**

This paper proposes a new hybrid propulsion system without large-capacity battery and clarifies its characteristics. This proposed system has main engines and diesel generators as power sources. These are connected through the electric power converters and the motor generators. To evaluate the propulsion system, a fuel consumption simulation has been developed. The simulation includes the efficiency data of all apparatus which comprise the propulsion system. The efficiency data varies depending on the load factor and rating of the apparatus. Considering all possible energy flows, the most efficient energy flow and power balance are determined. This simulation was evaluated using a tugboat's propulsion system as a model. In this paper, the characteristics of the fuel consumption model are described as the core unit in the simulation. An efficiency improvement of more than a few percent is expected when the power demand is low.

Keywords: Hybrid propulsion system, Tugboat, Fuel oil consumption simulation

1. Introduction

The reduction of CO₂ emissions is a significant topic for all vessels. Introducing into a new technique of electronic control engine (e.g. 1-2), reduction of the fluid resistance by hull improvement (e.g. 3), antifouling paint (e.g. 4), air lubrication (e.g. 5) and weather routing navigation (e.g. 6) have been attracted attentions for reduction of fuel consumption.

This study focuses on a fuel consumption model by using harbor tugboat's propulsion system. Harbor tugboat in general is powerful small boat which is designed to pull or push large ship. The equipped main engine in harbor tugboat outputs around 3,000kW but its gross tonnage is just around 200 tons. To have been stability of the harbor tugboat when pushing and pulling large ship on high output power, the ratio of hull length and width is designed to be extremely small values comparing to general cargo ships. Therefore, it is fundamentally difficult to reduce fuel consumptions and exhausting CO₂ by improving the fluid resistance of hull.

Consequently, the development of the hybrid tugboat has been progressed in the globe⁽⁷⁻¹¹⁾. These propulsion systems

Lithium-ion battery is a dominant device as the large-capacity battery because its energy density and power density are extremely high comparing to other type of batteries. However, it is not as low lithium-ion battery price as it is anticipated today. No hybrid system with the large battery can go without an official finance support. In this paper, it is discussed to approach to a hybrid type tugboat not by using battery, to clarify the characteristics of the proposed propulsion system and its operation procedures. To evaluate the system performance, FOC (fuel oil consumption) model is developed for simulating consumed fuel oil quantity⁽¹²⁾. Under these simulations, it is estimated the energy efficiency of the device rating and the loading factor. It is also covered every energy flow possibility.

The core of simulation is consisted of the data bank for estimating efficiency and control system (Fig.1)⁽¹³⁾. Giving the value of main engine's rated power and diesel generator's rated power into the simulation core, the fuel consumption model of the propulsion system is attained. It is possible to achieve the total FOC of the propulsion system by operating the model with characteristic load fluctuation pattern of tugboat.

In this paper, the structure of FOC model is described with efficiency estimating data bank of engines, electric machines, and mechanical transmissions. Furthermore, the trends and characteristics of achieved FOC model are discussed.

* Received January 29, 2015

**Tokyo University of Marine Science and Technology
2-1-6 Etchujima, Koto-ku, Tokyo, JAPAN

include a large-capacity battery as a part of power source.

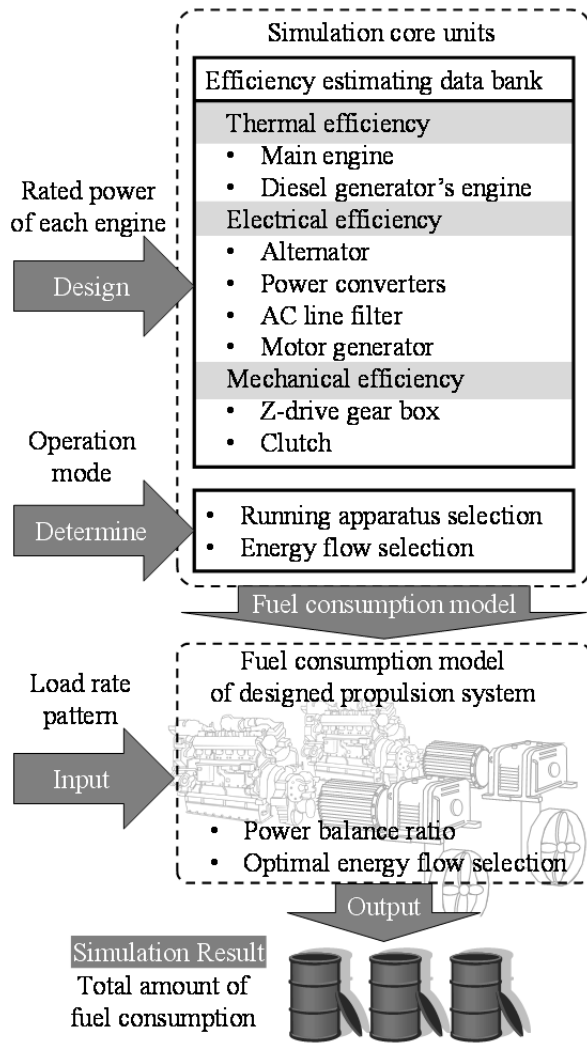

Fig.1 Consist of simulation

2. Tugboat features and configuration of propulsion system

2.1 Tugboat features

Fig. 2 shows a sample of observed main engine's load rate and the engine speed. In general, the main engine's load rate of tugboat fluctuates frequently as compared to the general cargo ships because of its work that tugboat assist maneuvering of large vessels. As is clear from the sample of load rate fluctuation pattern, high-loaded time is extremely short. On the other hand, low-loaded time is long.

2.2 Conventional tugboat system

A conventional tugboat system is illustrated in Fig. 3. The propulsion system and electrical power system are installed independently in a conventional tugboat. The propulsion power is produced by the main engine (M/E) and is transferred to the azimuth thruster through the intermediate shaft, clutch, and z-drive gear box. By almost all tug boat, two

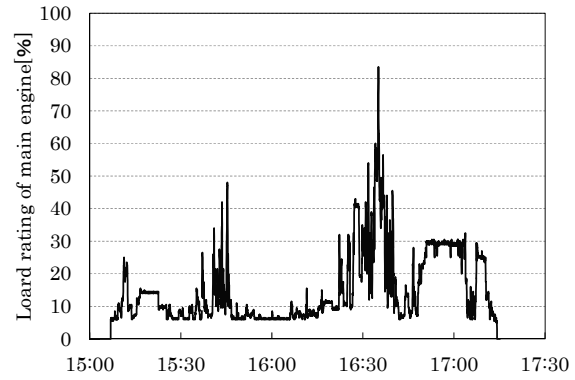

Fig.2 Fluctuation of load rating of main engine

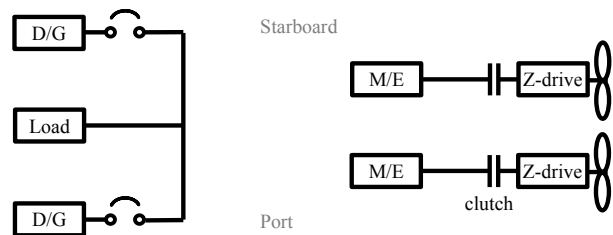

Fig.3 System of conventional tug boat

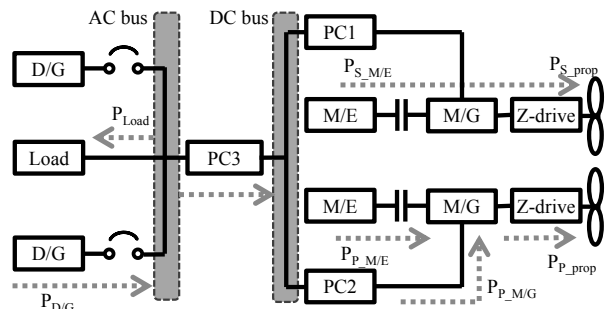

Fig.4 Proposed propulsion system and an example of energy flow

or more sets of azimuth thruster are installed for the purpose of enlarging a bollard thrust force and making maneuverability performance high. For this reason, same number of main engine is equipped. The diesel generators (D/G) supply demand for electrical loads in the ship.

2.3 Proposed tugboat system

Fig. 4 shows a new proposed tugboat system. Main engine system and electrical power one are connected with motor generator (M/G) and electric power converter (PC1, PC2, and PC3). The motor generator is also directly connected to the main shaft in gearless. In the proposed systems, the flexibility of energy flow is enhanced. For example, it is possible to share the demanded propulsion power of both propellers by one main engine when the demanded power is low. In the results, the energy flow patterns would be diversified in the new proposed system.

The energy flow patterns classify into 32 categories depending on driving numbers of the main engines, generators and energy direction of motor generators. Moreover, the rating power of the main engine and of the generator can be assumed as a designed parameter.

3. Calculation scheme in fuel consumption model

In Fig.4 the power of the main engine of the starboard P_{S_ME} is transmitted to propellers by the clutch and Z drive mechanism. Following equation is to be introduced in case that the transfer efficiencies assume the clutch and Z drive mechanism as η_{clutch} , η_z .

$$P_{S_prop} = P_{S_ME} \times \eta_{clutch} \times \eta_z \quad (1)$$

In this paper, η_{clutch} is defined as a function of the slip rate of clutch. After fitting clutch, η_{clutch} is assumed to be constant. In the portside, the part of generator power $P_{D/G}$ is supplied to the main shaft through the electric converters and motor generator power. The motor generator power P_{P_MG} is given as followings.

$$P_{P_MG} = (P_{D/G} - P_{Load}) \times \eta_{PC3} \times \eta_{PC2} \times \eta_{MG} \quad (2)$$

where, η_{PC3} is AC bus side of power converter's efficiency, η_{PC2} is the motor generator side of power converter's efficiency, η_{MG} is the motor generator's efficiency and P_{load} is onboard electric demand. In this study, efficiency of each apparatus composing of propulsion system is expressed as a function of output ratio in their ratings respectively. The estimation functions of efficiency are discussed after Chapter 4.

Resultant propulsion power P_{P_prop} comes from both the main engine P_{P_ME} and the motor generator P_{P_MG} in the portside. Given following expressions in case that the power balance ratio of the main engine output is shown k and that of motor generator output is shown $(1-k)$ in the composition output.

$$P_{P_ME} = \frac{k \times P_{P_prop}}{\eta_{clutch} \times \eta_z} \quad (3)$$

$$P_{P_MG} = \frac{(1-k) \times P_{P_prop}}{\eta_z} \quad (4)$$

Note: $0 \leq k \leq 1$

In addition to the above equation, the fuel consumption of main engine q_{S_ME} [l/sec] in starboard side, q_{P_ME} [l/sec] in port side, and diesel generator $q_{D/G}$ [l/sec] are achieved by considering the thermal efficiency of main engine η_{S_ME} , η_{P_ME} and diesel generator's efficiency $\eta_{D/G}$.

$$q_{S_ME} = \frac{P_{S_prop}}{\eta_{clutch} \times \eta_z \times \eta_{S_ME}} \quad (5)$$

$$q_{P_ME} = \frac{k \times P_{P_prop}}{\eta_{clutch} \times \eta_z \times \eta_{P_ME}} \quad (6)$$

$$q_{D/G} = \frac{(1-k) \times P_{P_prop}}{\eta_{D/G} \times \eta_{PC3} \times \eta_{PC2} \times \eta_{MG} \times \eta_z} + \frac{P_{load}}{\eta_{D/G}} \quad (7)$$

Consequently, the total fuel consumption q_{total} [l/sec] in the energy flow of Fig.4 is calculated as follows.

$$q_{total} = q_{S_ME} + q_{P_ME} + q_{P_D/G} \quad (8)$$

q_{total} is given as a function of η_{PC3} , η_{PC2} , η_{MG} , $\eta_{D/G}$, η_{S_ME} , η_{P_ME} , P_{S_prop} , P_{P_prop} , and k in this case. In this study, all function of q_{total} in all possible energy flows was derived. There are 32 patterns of possible energy flow in the proposed propulsion system. The fuel consumption models are consisted of the above functions and the operation mode selection mentioned in Chapter 6.

All the data measuring of the efficiency referred to in this paper is the values in a steady state, and the data adopted in the efficiency estimation data bank is also an efficiency value of a steady state. The response delay of a turbocharger occurs and thermal efficiency changes transitionally, when engine load changes rapidly in fact. However, the data of the efficiency in such transient state is difficult to get. Moreover, many of engines installed in an actual tug boat are mid-high speed 4 cycle engines, and their load following capability is high enough as compared with the low speed 2 cycle engine of other cargo vessels. Consequently, the calculation for estimating fuel consumption was implemented without distinguishing transient state and steady state.

4. Efficiency of engines and motor generator in data bank

4.1 Rated power and Efficiency

Efficiency of the main engine, diesel generator and motor generator is different, depending on respective rating outputs and those driving loading factor. In this research, it is estimated the respective apparatus efficiency by using the actual data from the several completion drawing books of substantial vessels. Furthermore, the gear and clutch efficiency are fixed without any relation to the rating and loading factor.

Fig.5 shows the tendency of the efficient in the condition that the apparatus operates at the rated power. As it is shown, the bigger rated power is the higher efficient value is in linearly-extended and in logarithmically-converged. The rated power of apparatus is higher, they come to high

efficiency and the efficient improvement tends to be saturated in general. In this research, it is figured out the relationship of rated power and efficiency whether it is linear type or saturated one.

Within the limits of collected efficiency data, relation of rating size of apparatus and its efficiency was linearly extended. On the other hand, the efficiency of M/G became logarithmic convergence. The permanent magnetic motor is adopted as M/G for the purpose of downsizing and improving efficiency.

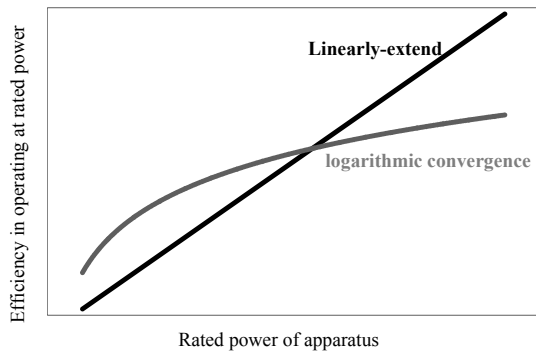

Fig. 5 Relation of rating size of apparatus and its efficiency

4.2 Loading factor and Efficiency

Given different rated-power apparatus (Rate S or U), the efficient features by loading factor are imaged on actual data in Fig.6. As far as authors have investigated, the rated power is larger, the efficiency is higher and the loading factor is higher, the efficiency is higher.

An apparatus of rated-power T (S<T<U) is estimated the efficient characteristic curve. Following function is defined the efficiency η_S or η_U as to the loading factor S or U in the apparatus.

$$\eta_S = f(x), \eta_U = g(x) \quad (9)$$

In this condition, the rating T efficiency η_T is set in linearly extended type as below.

$$\eta_T = \frac{(U - T)f(x) + (T - S)g(x)}{U - S} \quad (10)$$

On the other hand, it is set in logarithmic convergence type as below.

$$\eta_T = \frac{\ln \frac{U}{T} f(x) + \ln \frac{T}{S} g(x)}{\ln \frac{U}{S}} \quad (11)$$

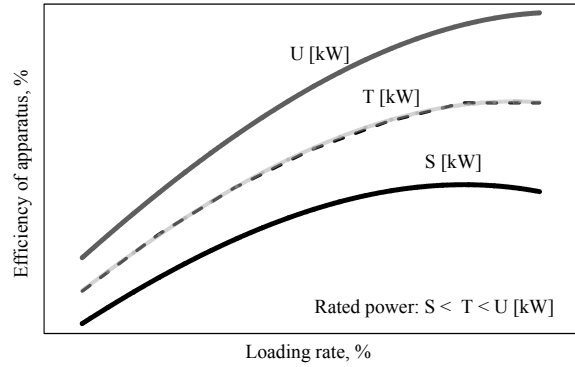

Fig. 6 Relation of loading factor and its efficiency

5. Electrical power converter

5.1 Circuit configuration

As shown in Fig.4, the electrical power converter system proposed in this paper is constituted by PC1, PC2 and PC3. These converters connect the main shaft and the AC distribution system, and then control the electric power, direction of energy flow and current waveform. An electrolytic capacitor which is put in DC bus represents the smoothing capacitors of PC1, PC2 and PC3 respectively (see Fig.7 and Fig.8). The power can be transferred and shared between each main shaft for not going via AC bus, because the motor generators of port side and starboard side are connected by PC1, DC bus and PC2.

PC1 and PC2 connect the DC bus and the motor generator respectively. These operate in PWM scheme to suppress the torque ripple of the motor generator and to control the electric power and its frequency.

PC3 connects the AC distribution system and DC bus. The electric system voltage is 220V in the conventional tugboat. On the other hand, the system voltage is raised up to 440V in the proposed propulsion system so that electric power loss is controlled when the generator outputs large electric power.

PC3 supplies sinusoidal AC power by its PWM control when the electric power is transferred from DC bus to AC bus. AC line filter have to be installed between AC bus and PC3 to eliminate the switching frequency included in output voltage. Taking account of the THD (Total Harmonic Distortion) problem at AC distribution system, PC3 should be controlled in PFC (Power Factor Correction) operation to improve current waveform when the power is transferred from AC bus to DC bus. At this time, the operation of PC3 becomes a boost operation due to the inductance of AC line filter. Therefore DC bus voltage is set to 700V.

The power electric converters employ 6 IGBTs (1200V/600A) as the switching devices. The converter constituted from these IGBTs shall be 1 block, and two or more blocks are connected in parallel depending on the conversion power. The number of converter blocks has to be determined so that an expected maximum power can be converted.

The number of use of the converter block is changed depending on the output/input current. When carrying out the parallel run of the converter block, it is assumed that current flows equally into the whole block under parallel operation in this paper.

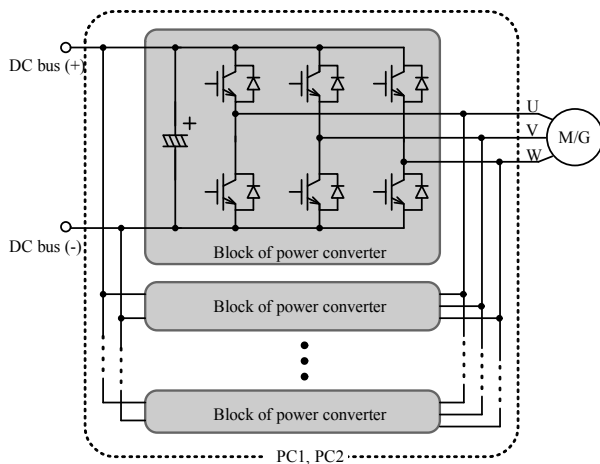

Fig. 7 Circuit configuration of PC1 and PC2

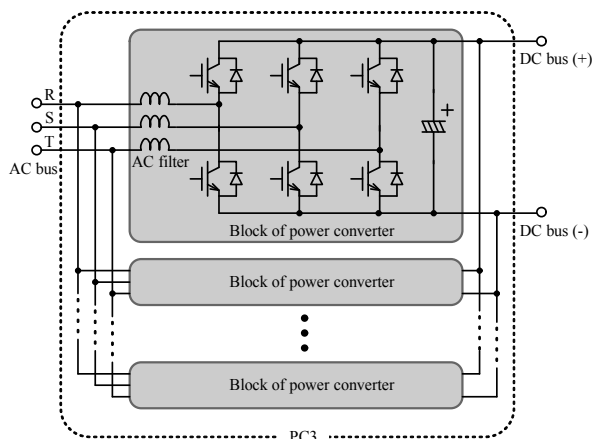

Fig. 8 Circuit configuration of PC3

5.2 Efficiency of electric power converter in data bank

The efficiency of electric power converter is achieved from a simulation which is released by a device supplier. In the simulation, the collector current of device, DC bus voltage, the saturation voltage, the switching frequency, and the switching loss are taken into consideration. The electric power for the gate driving, the controller, and the cooling

device is not based on the conversion power, but is set constant.

The output voltage and frequency of PC1 and PC2 are calculated by the speed of main shaft and torque balance order which are attained from a back calculation of the demanded propulsion power. The power factor of M/G is not based on its load rate but is set constant because whole calculation is carried out not in transient state but in steady state in this paper.

The switching frequency of PC3 is set to more highly than others since it is necessary to care about the THD of AC system. The power factor of AC system is set to 0.8 which is a standard value in ship.

Table 1 Simulation condition of power electronics converter

	PC1, PC2	PC3
IGBT device	1200V/600A	1200V/600A
Switching frequency	2.5kHz	5.0kHz
Power factor	0.95	0.80

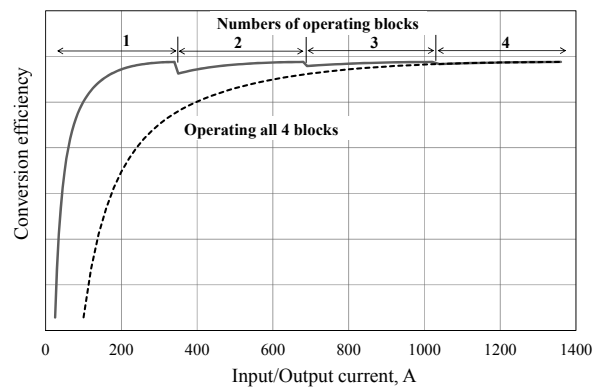

Fig.9 Conversion efficiency of PC3

Fig.9 indicates the power conversion efficiency of PC3 achieved from the power electronics simulation released by a semiconductor device supplier. Simulation result shows the efficiency characteristics in the condition that PC3 includes 4 converter blocks.

The efficiency comes to be low when its output/input current is small. If all 4 converter blocks operate in parallel at any condition, the trend of efficiency becomes dotted line in the figure. On the other hand, there is a possibility to improve the efficiency by optimizing the number of converter blocks which operate in parallel depending on the input/output current like a solid line in the figure. Since IGBT is used at derating 80% of the rated current, every the output current per block becomes over a certain value which is 340A in this paper, the number of blocks under operation increase. As a result, the conversion efficiency changes

slightly around the borders of 340A.

Fig.10 shows a power conversion efficiency of PC1 and PC2. As M/G is a permanent magnetic synchronous machine, the terminal voltage depends on its rotation speed. In the same way, the input/output current flowing through M/G is changed by the speed even if the power is constant. So, PC1 and PC2 have an efficiency map. Basically, the higher voltage inverter output, the higher efficiency is obtained.

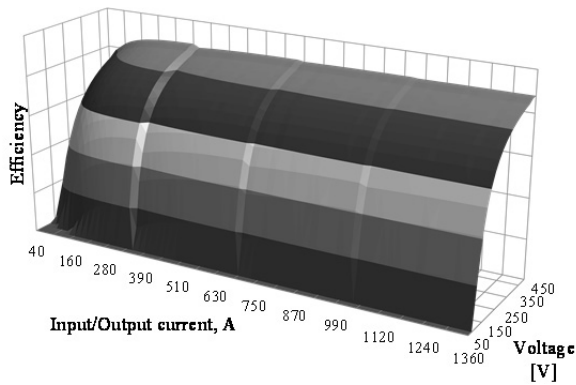

Fig.10 Conversion efficiency of PC1 and PC2

6. Operation modes

6.1 Mode classification

Tug boat's operation is classified into 3 modes that one is "service mode", second is "waiting mode" for service and last is "out of service".

If idling stop is possible in a tugboat like the latest car, as an average load of tug boat's main engine is low, the remarkable improvement in efficiency is expectable. However, in fact, since the piston of a ship main engine and the moment of inertia of a crankshaft are very large, it is difficult to start and to operate engines quickly for demand fluctuation. So, in this study, an engine stop and restart within each mode were forbidden.

6.2 Feature of each modes

Fig.11 shows a converted data of fig.2 which is classified into 3 modes. Duration time that main engine's load is high is quite short. The service mode is that a tugboat is on service to pull or push large vessel and the propulsion force changes widely from low to high. As is clear from Fig.11, the large power is rarely used. However it is necessary to prepare so that the tugboat outputs large power depending on the situation. Consequently, all main engines and a generator should be running while in this mode.

The tugboat arrives at the working place before starting operation for a large vessel, and waits until the pilot boards the large vessel. In a conventional tugboat, the clutch is to be off and all main engines are to be idled to keep the tug boat's position. As large power is hardly used in waiting mode, it is enough that one main engine runs for waiting in the proposed propulsion system.

The out of service mode is a condition that the tugboat transfers between its base port and the working place in harbor. In this mode, the range of required power is low to middle. It is enough if one main engine and one generator are running in the proposed system.

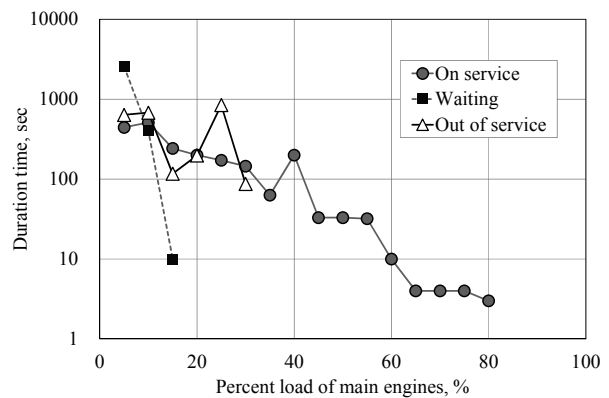

Fig. 11 Duration time in classified modes

7. Simulation on fuel consumption

7.1 Sample of simulation condition

The total fuel consumption is calculated by using the developed simulation. Table 2 shows the simulation conditions of the conventional tug boat. In many cases, the main engines of around 1,500kW rating are equipped 2 sets. AC bus voltage is 220V as the onboard electric demand is small.

Table 3 shows the simulation condition of the proposed hybrid tug boat. The rating of motor generator is designed so that both side propellers are driven by one main engine and one diesel generator as the power sources in this sample simulation condition. PC1 operates under PFC (Power factor correction) control in order to improve harmonic distortion on AC bus when it converts 3-phase 440V to DC voltage. DC bus voltage is set to 700V as PFC is boost operation.

Table 2 Simulation condition of conventional tug boat

item	rating	number
Main engine	1,500kW	2 sets
Diesel generator	100kW	2 sets
AC bus	220V, power factor=0.8	

Table 3 Simulation condition of proposed hybrid tug boat

item	rating	number
Main engine	1,350kW	2 sets
Diesel generator	300kW	1 set
Motor generator	860kVA	2 sets
PC1	680A	2 blocks
PC2, PC3	1,360A	4 blocks each
AC bus	440V, power factor=0.8	
DC bus	700V	

7.2 Simulation result

The fuel consumption in the propulsion systems mentioned above is calculated by substituting the load fluctuation pattern and the main engine speed which is shown in Fig.2 as a sample to the fuel consumption model every second. Fig.12 indicates a sample of calculation result. The fuel consumption of the conventional system is set to the baseline. The vertical axis shows the increase and decrease of the fuel consumption of the proposed hybrid propulsion system compared to the conventional one.

In the waiting mode and the out of service mode, FOC of hybrid system is less than the conventional one. Especially the total demanded power is below to 20%, hybrid system can save FOC considerably. On the other hand, FOC of hybrid system increases when the demanded power is high in service mode.

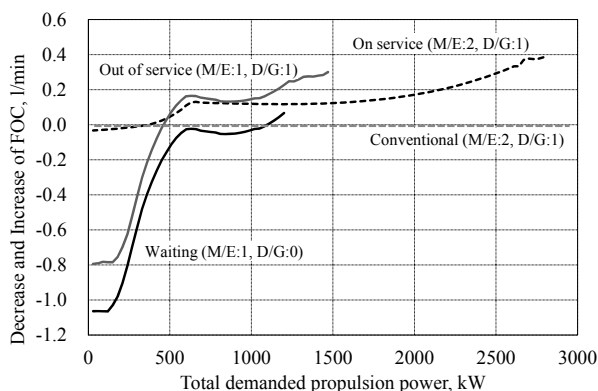

Fig.12 Decrease and increase of FOC comparison with conventional system

7.3 Consideration to simulation results

The diesel engine's thermal efficiency is extremely low when it operates at low load rating for example under 20%. As the total demanded propulsion power is low in the waiting mode and the out of service mode, FOC of the conventional system tends to increase. In the proposed hybrid system, one main engine can be stopped and another engine acts as a power source for both side propellers. The load rating of the operating engine becomes high. Consequently it is possible to improve FOC in the proposed hybrid system even if considering power loss in the M/G and the electric power converters. In waiting mode, PC1 can be substituted as an electric power source for onboard electric load. Then D/G can be stopped, and the efficiency of whole system is improved. In addition, in the tug boat's operation, the duration time of waiting mode and the out of service mode is long obviously as shown in Fig.11. Therefore, the improving effect of FOC can be achieved by introducing the hybrid system without battery for the tug boat.

8. Conclusion

In this study, the simulation for calculating the fuel oil consumption in the propulsion system is developed in order to clarify the improving effect of hybrid system. The simulation has several actual efficiency data of in every apparatus including engine for estimating. And the efficiency of each apparatus can be estimated in any designed condition and in any load rating condition. By implementing the simulation in a certain designed condition, FOC of hybrid system was compared to the conventional one. Resultantly, it is shown that the hybrid system is effective for tug boat propulsion system.

References

- (1) State-of-the-Art Electronically Controlled Marine Engine Production, New Horizons, Publication of Hyundai Heavy Industries, January-February, p.7 (2005)
- (2) Masahiko OKABE, Katsuhiko SAKAGUCHI, Masahide SUGIHARA, Akihiro MIYANAGI, Naohiro HIRAOKA, Satoru MURATA, "World's Largest Marine 2-Stroke Diesel Test Engine, the 4UE-X3 - Development in Compliance with the Next Version of Environmental Regulations and Gas Engine Technology -", Mitsubishi Heavy Industries Technical Review Vol. 50. No. 1, pp.55-62, (March 2013)
- (3) "Ax-Bow: A New Energy-saving Bow Shape at Sea", NKK

- TECHNICAL REVIEW, No.86, pp.46-47 (2002)
- (4) Naoki YAMAMORI, Mamoru SHIMADA, "Verification of the Reduction effect of New Antifouling paint for ship bottoms "LF-Sea®" on the Friction Resistance by utilizing Actual Ships", TECHNO-COSMOS, Vol.22, pp.28-33, 2009 March
 - (5) Shuji MIZOKAMI, Manabu KAWAKADO, Mitsuhiro KAWANO, Takeo HASEGAWA, Ichiro HIRAKAWA, "Implementation of Ship Energy-Saving Operations with Mitsubishi Air Lubrication System", Mitsubishi Heavy Industries Technical Review Vol. 50 No. 2, pp.44-49 (June 2013)
 - (6) K. Takashima, B.Maoui, R. Shoji, "Optimum Operation of Coastal Merchant Ships with Consideration of Arrival Delay Risk and Fuel Efficiency", Marine Navigation and Safety of Sea Transportation, pp.149-155, 2011.
 - (7) Gary Faber, Jason Aspin, "The Foss Hybrid Tug: From Innovation to Implementation", Proc. of The 20th International Tug & Salvage convention and exhibition, pp.149-156 (2008)
 - (8) John Pagni, "New GREENER LNG TUG CONCEPT", Wärtsilä Stakeholder Magazine Twentyfour7, Vol.03, pp.64-65 (2008)
 - (9) Paul Jamer, John Eldridge, Aspin Kemp, "Conversion of Kotug's RT Adriaan to become Europe's First Hybrid Tugboat", Proc. of The 22nd International Tug, Salvage & OSV convention and exhibition , pp.209-223 (2012)
 - (10) Masayoshi Kawakami, "Future impacts on ship safety: Future Engine Systems", IMO Symposium on the Future of Ship Safety, 2013 (June)
 - (11) Fuel Economy: Hybrid Solutions and Beyond, Dirk Degroote, Robert van Koperen, Proc. of The 23rd International Tug, Salvage & OSV convention and exhibition , pp.77-86 (2014)
 - (12) Hiroyasu Kifune, Takaaki Nishio, "A study on hybrid propulsion system without battery for tug boat", Proc. of International Symposium on Marine Technology 2013, pp.193-196 (2013)
 - (13) Takaaki Nishio, Hiroyasu Kifune, "A study on simulations of fuel consumption in hybrid propulsion system for tugboat" ,Proc. of The International Symposium on Marine Engineering 2014 in Harbin, PID150 (2014),